

H2DA2* - 122

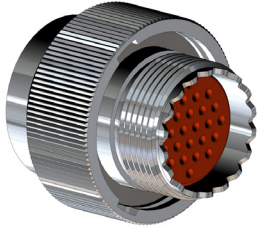

The HiRel **H2DA2*-122** High Density Self-Locking Plug is designed with a double start ACME thread and a rear accessory thread that is compatible with an exterior backshell. HiRel has incorporated the patented Self-Locking mechanism into this plug, which has proven to stay locked under extreme vibration. This H2D plug is available in shell sizes 5-21 with any of our standard insert arrangements as well as custom configurations.

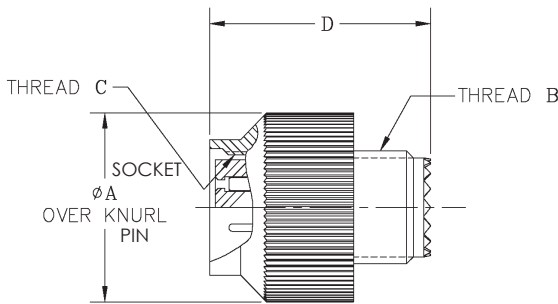

Testing	
Operating Temperature	-65°C to +175°C*
Random Vibration	37g
Shock	300G, half-sine, 3ms, 3 axes
Gunfire Vibration	37g

TABLE 2

SHELL SIZE	Ø A MAX.	THREAD B UNS-2A	THREAD C	D MAX.
05	.613	.2840-32	.3125-.05P-.1L-2B	.910
06	.665	.3370-32	.3750-.05P-.1L-2B	.910
07	.748	.4375-28	.4375-.05P-.1L-2B	.910
08	.785	.4740-28	.5000-.05P-.1L-2B	.910
09	.847	.5370-24	.5625-.05P-.1L-2B	.910
10	.920	.6090-24	.6250-.05P-.1L-2B	.910
13	1.032	.6875-24	.8125-.1P-.2L-2B	1.075
16	1.221	.9375-20	1.0000-.1P-.2L-2B	1.075
17	1.282	.9375-20	1.0625-.1P-.2L-2B	1.075
21	1.550	1.1875-18	1.3125-.1P-.2L-2B	1.075

TABLE 3

MINOR KEY ANGLES		
POSITION	F°	E°
A (NORMAL)	150°	210°
B (ALTERNATE)	75°	210°
C (ALTERNATE)	95°	230°
D (ALTERNATE)	140°	275°
E (ALTERNATE)	75°	275°
F (ALTERNATE)	95°	210°

H2DA2*-122

H2DA2*-122-**-*****

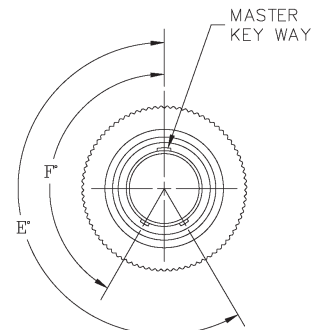

* See "Classes/Finishes" table for exceptions

INSERT ARRANGEMENTS

Front face of pin insert engagement side shown. Socket insert is mirror image of pictured.

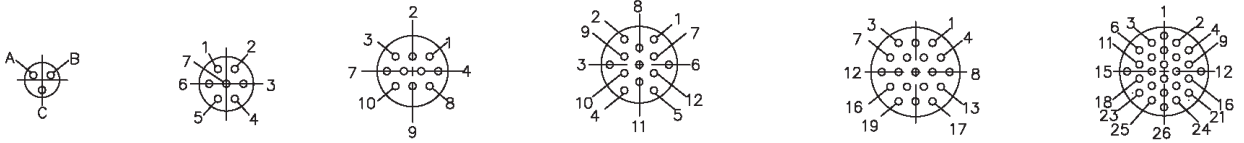

Insert Arrangement	05-003	06-007	07-010	08-013	09-019	10-026
No. of Contacts	3	7	10	13	19	26
Contact Size	#23	#23	#23	#23	#23	#23
DWV Voltage (VAC)	500	500	500	500	500	500
Current Rating (Amps)	5	5	5	5	5	5

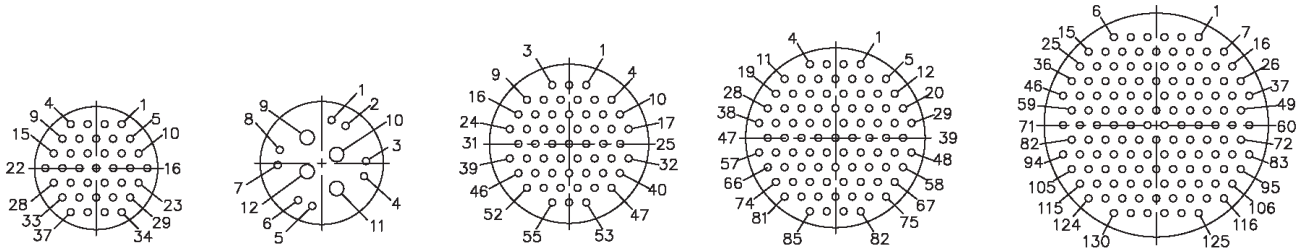

Insert Arrangement	13-037	13-048	16-055	17-085	21-130
No. of Contacts	37	4	8	55	130
Contact Size	#23	#16	#23	#23	#23
DWV Voltage (VAC)	500	1800	500	500	500
Current Rating (Amps)	5	13	5	5	5

CONTACTS



Contact Pin:

Contact Socket:

Size 23

Size 23

0009-047-000 (22-24 AWG Wire)	0012-049-000 (22-24 AWG Wire)
0009-114-000 (26-28 AWG Wire)	0012-287-000 (26-28 AWG Wire)

CLASSES/FINISHES

Class	Material	Finish
C	Al	Anodize Black**
F	Al	Low Stress Nickel**
W	Al	Olive Drab Cadmium over Nickel
T	Al	Nickel Teflon
Z	Al	Zinc Nickel
B	Ti	Nickel**
K	Cres	Passivated**

For Space Grade Applications, add a "1" after the Class.
Ex: Space Grade Titanium with Nickel plating = B1

** Operating Temperature -65°C to +200°C

TOOLS

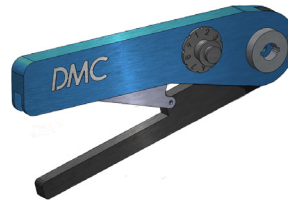

Crimp Tool:
Daniels P/N AFM-8
(M22520/2-01)



Positioner:
Daniels P/N K-710A (Socket)
Daniels P/N K-709A (Pin)



Insertion / Extraction Tool:
P/N 08AT024-23 (Size 23)

For hermetic connectors, alternate insert arrangements or connectors with size #16 contacts, please consult factory for more information.